

# PROEDGE

## INSTRUCTION MANUAL

**PTI** SECURITY  
SYSTEMS

---

**ASSA ABLOY**

2024

# PROEDGE

## Instruction Manual

### TABLE OF CONTENTS

Introduction .....	3
Getting Started.....	4-7
Removal Tools.....	8-9
Product Overview.....	10-12
StorID.....	13-14
Features .....	16
Components.....	17
Batteries .....	17-18
Physical Dimensions .....	19
Operations .....	20-23
Disposal.....	24
Frequently Asked Questions .....	25
Warranty.....	26-27

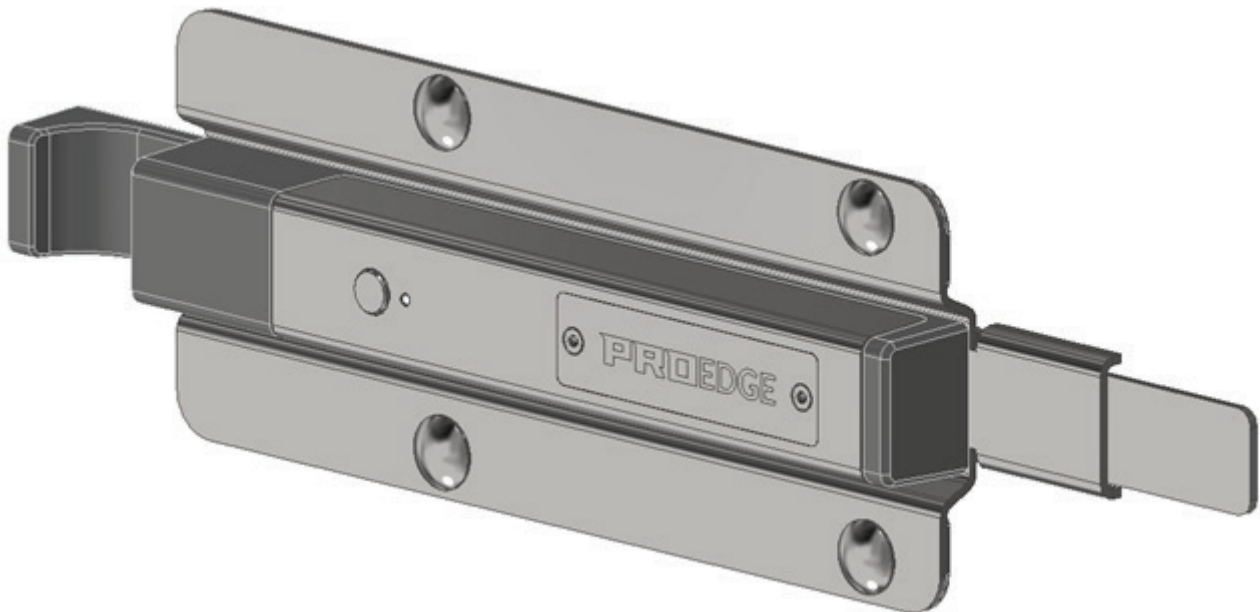

### PROEDGE INSTRUCTION MANUAL

Sales: +1.800.523.9504  
Support: +1. 866.240.7602  
Web: ptisecurity.com

Rev A – November 2023

#### INTRODUCTION

The purpose of this manual is to give the reader information related to the operation, maintenance and safety instructions of the ProEdge lock. The ProEdge lock has been certified for use in the NA, Europe and APAC.

#### INTENDED USE

The ProEdge lock is intended to be used in self-storage facilities, in conjunction with flat doors, corrugated doors and roll-up doors.

#### PRODUCT IDENTIFICATION

Each ProEdge lock is equipped with a unique serial number for identification and commissioning.

#### CE MARKING



The CE mark shows that the product complies with the relevant directives. See declaration of conformity at the manufacturer's website for more information. The product complies with the following directive(s):

- EMC directive (EMC) 2014/30/EU
- The low voltage directive (LVD) (2014/35/EU)
- The radio equipment directive 2014/53/EU (RED)

### IMPORTANT SAFETY INFORMATION

Read the following instructions very carefully before installing and maintaining the ProEdge lock. The ProEdge Lock contains a lithium battery.



**Note:** The battery should be stored and disposed of according to the manufacturer's specifications.



**Note:** The battery used in this product must be replaced by the same type of battery.



**Note:** The battery must not be punctured, charged or dropped, and should be replaced if so.

### GETTING STARTED – SYSTEM OVERVIEW

This section will give the reader an introduction to the ProEdge lock and what is included in the package.

#### Batteries





Batteries are not included in the ProEdge lock packages due to fire hazards. The ProEdge lock operates on a single battery with product name LM17500 and the manufacturer SAFT. Batteries can be ordered via PTI Security Systems: XXXXXX

### ProEdge lock – for corrugated doors

**SKU: 17000107**

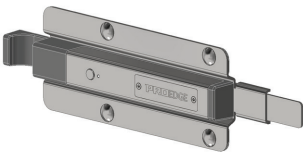
The ProEdge lock package contains the following items per lock:







One (1) ProEdge lock assembly - for corrugated doors		Four (4) M6 form A flat washers (DIN125)	
Four (4) M6 carriage bolt (DIN 603) A4		Two (2) Filt strips	
Four (4) M6 hexagon nylon locking nuts (DIN685) A4			

### ProEdge lock – for flat doors

**SKU:XXXXXXX**

The ProEdge lock box contains the following items per lock:

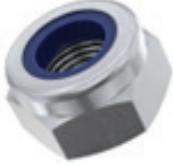



One (1) ProEdge lock assembly - for flat doors		Two (2) M6 carriage bolt (DIN 603) A4	
One (1) Backplate		Two (2) M6 hexagon nylon locking nuts (DIN685) A4	
One (1) Strike		Two (2) M6 form A flat washers (DIN125)	

### Gateway – SKU: XXXXXXXX

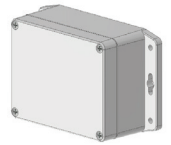
The ProEdge lock gateway box contains the following items:





1 x ProEdge gateway		1 x Power supply	
1 x Ethernet cable			

### Repeater – SKU: 17000110

The ProEdge lock repeater box contains the following items:



1 x ProEdge lock Repeater		4 x rawplugs	
4 x Torx Screws			

### Spare parts list

Item	SKU number
ProEdge Gateway Power Supply	XX
ProEdge Removal Tool for flat doors	XX
ProEdge Removal Tool for corrugated doors	XX
ProEdge Battery Cover	XX
ProEdge Lock Handle	XX
ProEdge mounting bolt - corrugated	XX
ProEdge mounting nut	XX
ProEdge mounting bolt - flat door	XX
ProEdge Repeater lid?	XX
ProEdge felt strips?	XX
ProEdge Repeater battery	17000114
ProEdge Lock battery	17000111
ProEdge mounting bolt - corrugated	17000112
ProEdge mounting nut	17000113

### REMOVAL TOOLS

The ProEdge lock comes with removal tools. 2 tools exist: One for corrugated doors and one for flat doors.

The main feature of the removal tool is to make any removal of decommissioned locks as easy as possible for the operator, and without the use of any power tools other than a drill.

#### Removal tool for corrugated doors

The removal tool is placed on the lock that needs to be removed.

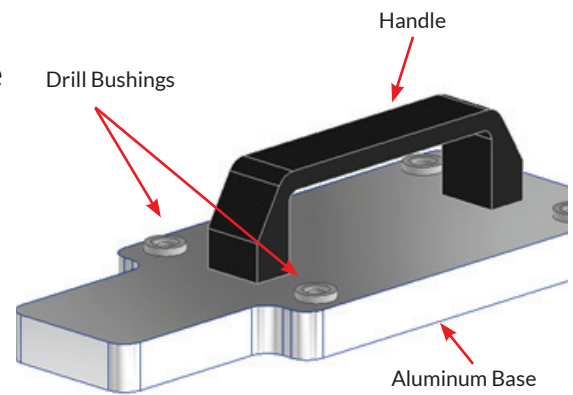

The aluminum base provides the same geometry as the housing of the lock.

The tool is pushed inwards and to the right-hand side until the 4x drill bushings align up with the carrier bolts.

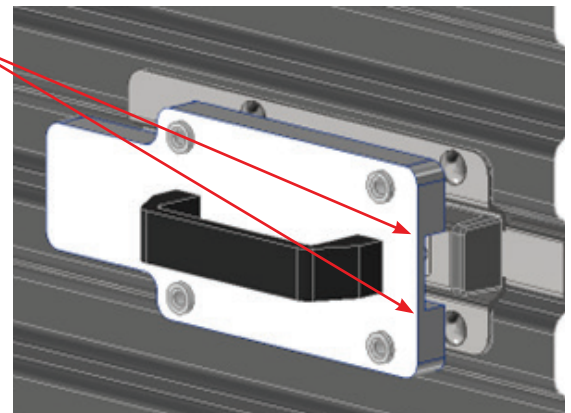

A drill with an Ø7mm drill bit is inserted and drilled through all 4x drill bushings.

This procedure will drill out the beginning of the thread for the bolts and the lock can then easily be removed.

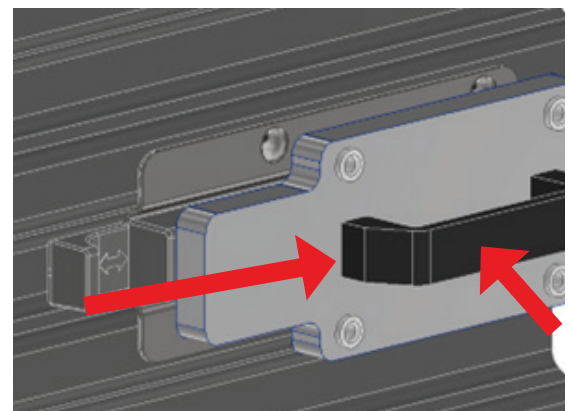



### Removal tool for flat doors

The removal tool is placed on the lock that needs to be removed.

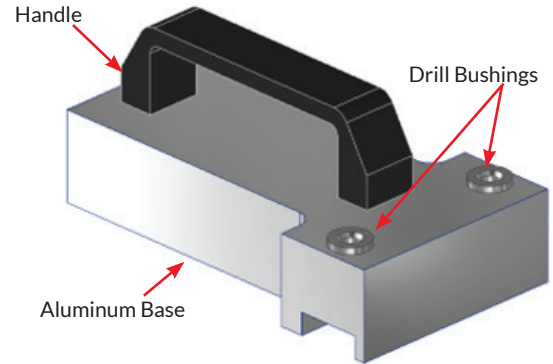

The aluminum base provides the same geometry as the housing of the lock and the strike plate.

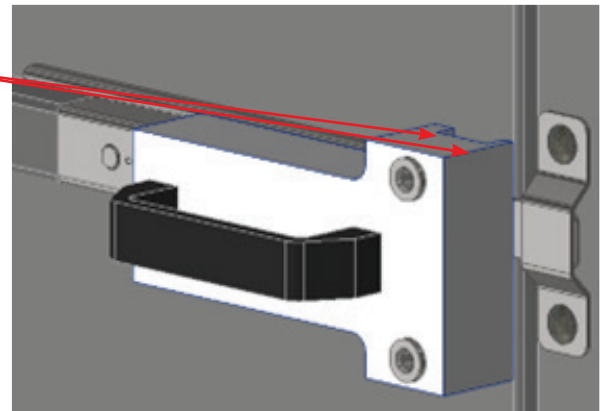

The tool is pushed inwards and the 2x drill bushings will align up with the carrier bolts.

A drill with an Ø7mm drill bit is inserted and drilled through 2x drill bushings.

This procedure will drill out the beginning of the thread for the bolts and the strike plate can then be removed and then the lock afterwards.

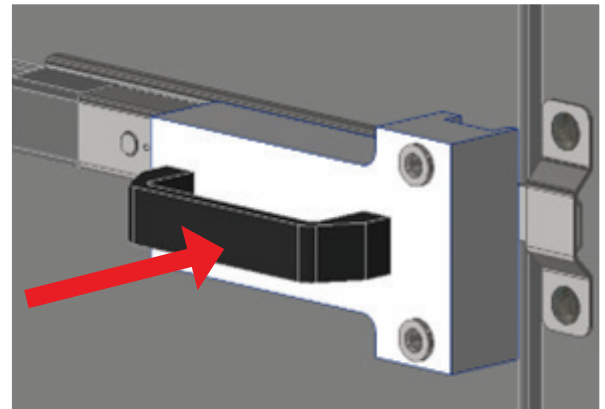

### Product Overview

The ProEdge lock has many components and component names. In the image provided, the different names are listed and should give the reader an overview of the names of each component.

### ProEdge Lock overview (Flat Door)

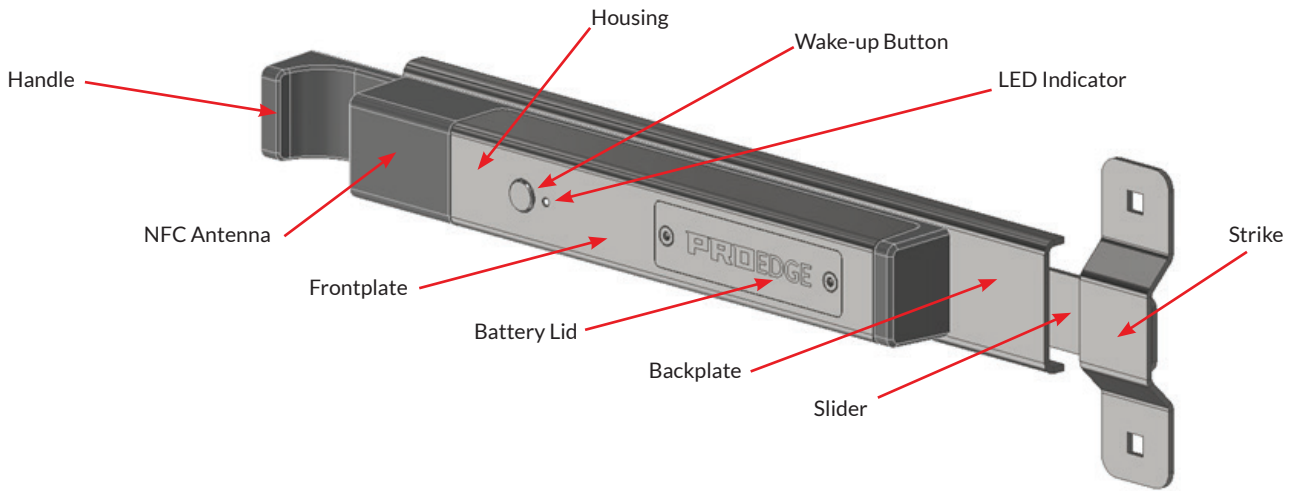

### ProEdge Lock overview (Corrugated Door)

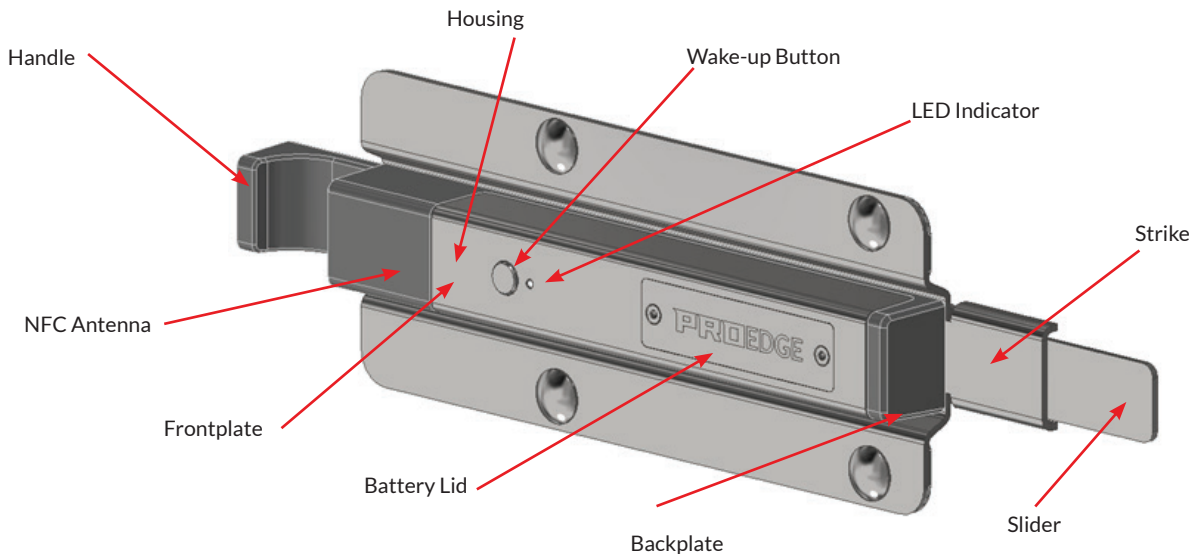

### ProEdge Lock Gateway overview

The ProEdge lock is equipped with a radio-module that, in conjunction with other locks, works as a network. This is called a mesh network.

The mesh network can, after all locks have been commissioned, pass on information from one lock to another, all the way to the gateway, and via the gateway and ethernet connection pass on the information to the cloud backend.

The image provided illustrates how a mesh network could look like.

- The red dot is the gateway, and after all locks have been commissioned and the gateway has been set up by the installer/commissioner, the network will be active.
- In case a lock is removed, decommissioned, or runs out of battery, the network will rearrange itself, or self-heal, and the remaining locks will connect to nearby locks.

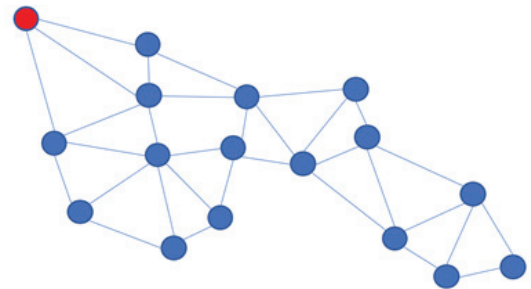

The mesh network that is generated by the radio module is called Mira Mesh.

All facilities that have the ProEdge locks installed must have at least 1 gateway and preferably more depending on the facility layout and number of units. As a rule of thumb, one gateway can handle 200 locks – but the installer/commissioner will decide how many gateways is needed taken network topology and facility layout into consideration.

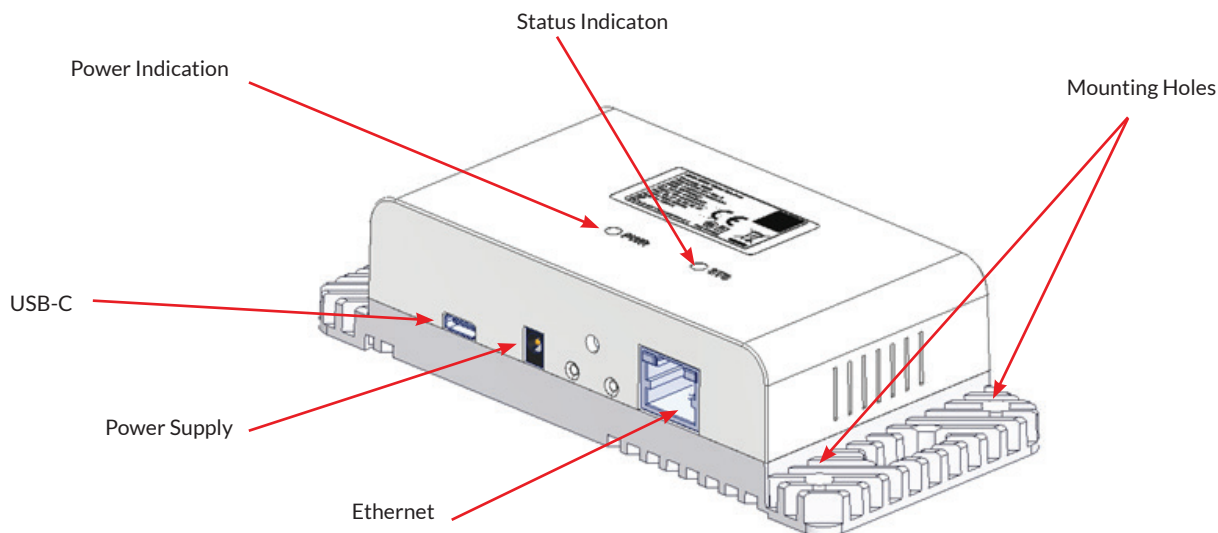

### ProEdge Lock Repeater Overview

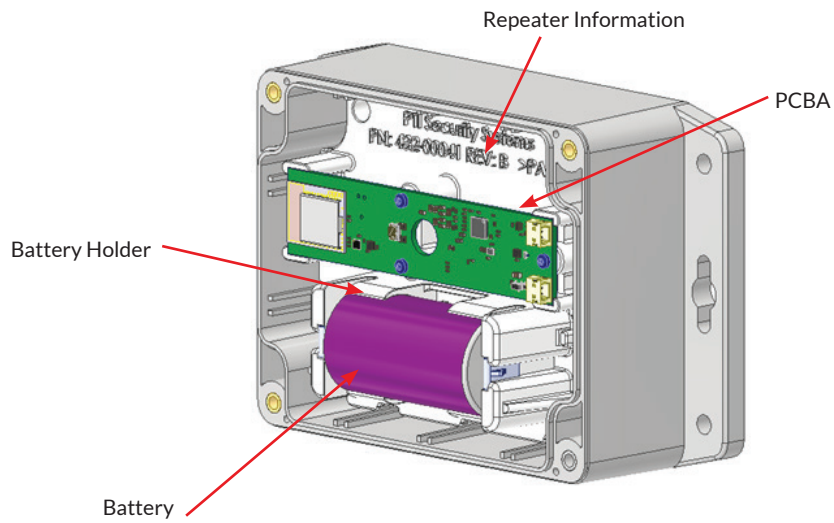
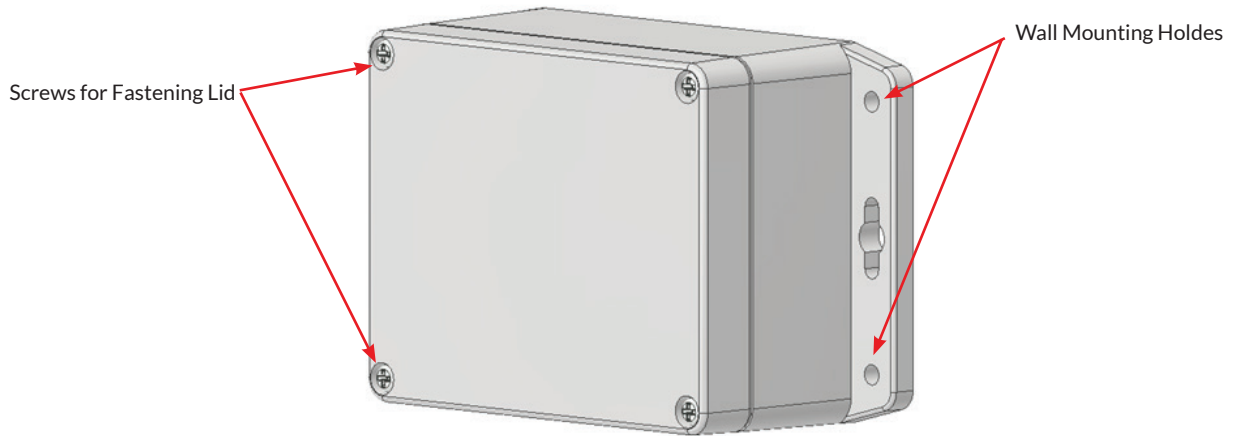

### ProEdge Lock StorID App overview

1. The StorID mobile application offers the following functions:
  - Enter/exit the facility with or without the phone (using Access Code to access the site).
  - View an audit trail detailing the history of facility and unit access.
  - Share access to the unit by providing others with a temporary digital key.
  - Handle the situation when the user is suspended and shouldn't be able to use the lock.
  - Receive tampering notifications in case of lock damage or breakage.
  - Suspend/unsuspend a tenant's ProEdge lock by rotating the derived keys, especially when the tenant is not fully paid and returns to good standing (In the SLC platform).
  - Activate presentation mode for proposed units, allowing the potential Tenant to inspect them (In the SLC platform).
  - Explore additional features recommended by the mobile application, such as integrated navigation using Google Maps (or alternative services), access to facility contact details, and the ability to pay rent within the app.
2. How to Unlock the ProEdge:
  - Upon login, verify that the Geofence, Bluetooth, Push notifications, Nearby device are turned on.
  - When the lock is woken up, it will appear in the list of active devices and identified with the help of BLE.
  - A modal appears featuring the active device, posing the question: "Do you wish to unlock the LOCK (serial number)?"
  - In uncommon situations, when the Tenant has access to multiple units located close to each other and after several locks are activated simultaneously, the modal window containing a list of them will be shown.
  - The Tenant will be presented with the option to choose a specific lock through a guiding text that reads, "Which lock do you want to unlock?"
  - Click on the desired lock.
  - Swipe right to unlock.
  - A lock opened successfully message will appear.
3. How to Share your Digital Key:
  - Navigate to the Key Sharing section in StorID.
  - Select the unit for which you would like to authorize access to another person.
  - Click the "Add new Keyshare access" button.

- Select the site, unit, type of share (time period, number of uses or permanent), and the applicable phone number for the user.  
If the Tenant has rented only one unit at a single facility, the Site and Unit dropdown fields will be pre-defined.

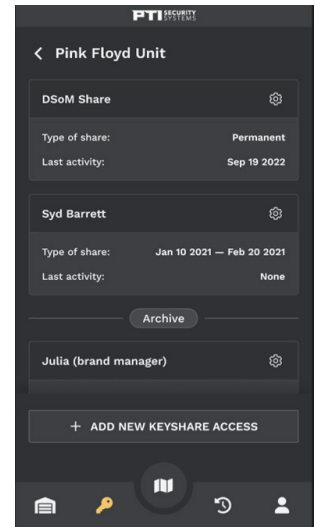

- If the Tenant has more than one unit rented at the facility or has access to more than one site, the option to choose will be available.
- Click the “Grant the Keyshare access” button.
- If the key-shared person is already enrolled in StorID, they will be granted access to the Tenant’s units.
- If the key-share person is not previously enrolled in StorID, they will receive the enrollment link, complete the registration, and ultimately gain access to the Tenant’s units.

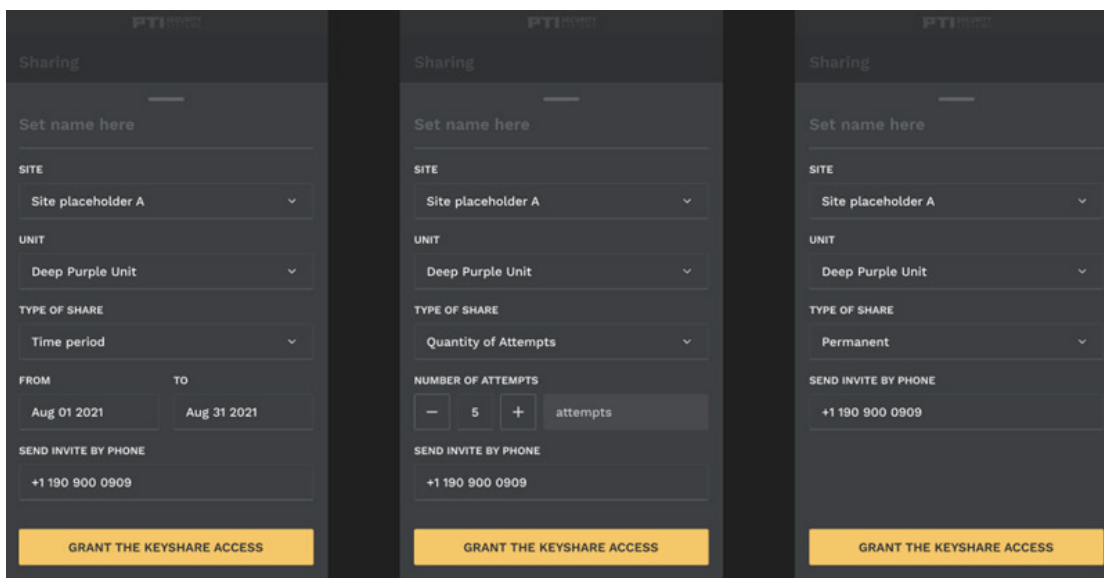
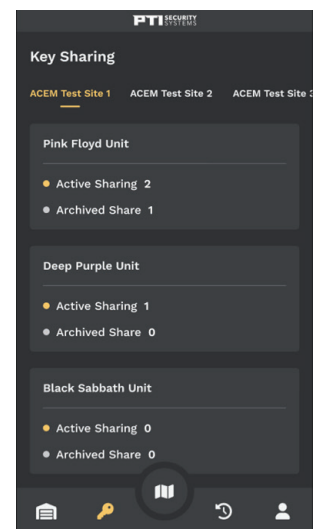

### Identification of the lock, repeater and gateway

The lock is equipped with a serial number and has model name: XX.....

The identification label for the corrugated version of the lock can be found on the backside of the lock (see the shaded area)

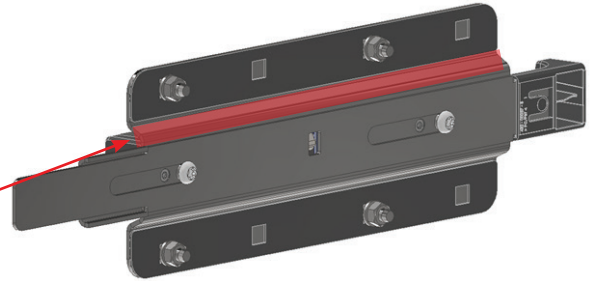

The identification label for the flat version of the lock can be found on the backside of the lock (see the shaded area).

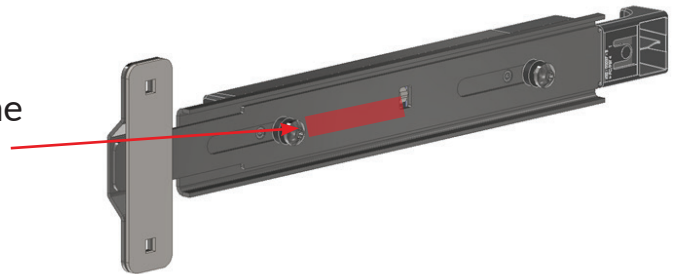

The repeater is equipped with a serial number which can be found inside when the lid is removed:

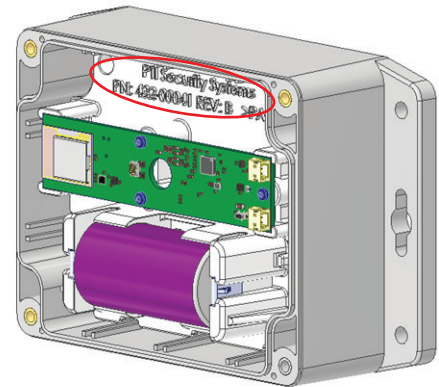

The gateway is equipped with a serial number which can be found on the front of the gateway:



### Key features

The ProEdge lock is equipped with a set of features:



**Internal accelerometer sensor:** The ProEdge lock is equipped with an X-Y-Z accelerometer sensor which can detect any sudden vibrations and tampering of the lock by detection in very small movements or break in with tools.



**Internal temperature sensor:** The Proedge lock is equipped with an internal temperature sensor that can detect variation in temperature within the lock and its surroundings. In case of sudden temperature changes, this data can be distributed via the MiraMesh network.



**Internal supercapacitor:** The ProEdge lock is equipped with a supercapacitor which is able to hold a charge to send out a sudden change in status. This could be triggered by a tampering event (Removal of battery) or sudden loss of voltage in the battery. The charge can hold up to XX minutes and can therefore sustain enough up-time to alert the backend before it loses power.



**NFC antenna:** The ProEdge lock is equipped with an NFC antenna, within the lock behind the black part of the plastic housing. The NFC antenna can communicate with a smartphone or NFC tag/card. It needs to be in the vicinity of the lock and black area.



**Bluetooth:** The ProEdge lock is equipped with Bluetooth Low Energy (BLE) and is accessed with the StorID app and a smartphone. With a press of the “wake-up” button, Bluetooth is activated, and the lock can be accessed.



### Physical components

The interface of the ProEdge lock is the button and LED indicator on the front of the ProEdge lock as well as the StorID app.

**Button:** The ProEdge lock is equipped with a button. The function of the button is to wake the lock up from its sleep mode. The lock is put into a sleep mode to save power.

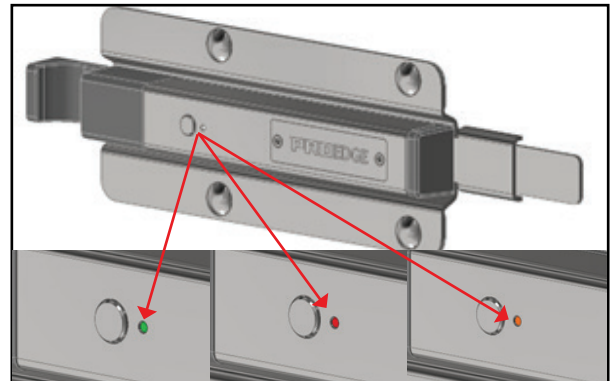

**LED indicator:** The Proedge lock is equipped with an LED indicator. The indicator will show the status of the lock during lock/unlock operation (Red/Green) and other colors indicating issues (Orange for example).



In sleep mode, the LED is off.

### Power source

The ProEdge lock is equipped with a single LM17500 battery that operates with 3V and holds a capacity of 3Ah. The rated lifetime of the battery with the lock is 3 years with 6 cycles (unlock/lock) per day.



It is important that the battery is replaced by the same battery type: LM17500.



The battery is not rechargeable and must be disposed of according to the manufacturer's specification.

### CHANGING BATTERIES

This section provides instruction on properly changing the batteries in the ProEdge lock and ProEdge lock repeater.

#### ProEdge Lock



Make sure to put the lock in “Battery changing mode” via the commissioning app to avoid any alarms in the backend.

1. Unscrew the 2 x battery screws on the front
2. Remove the screws and the lid
3. Take out the used battery and replace it with a new battery
4. Re-assemble the lid and screws
5. The batteries have now been replaced

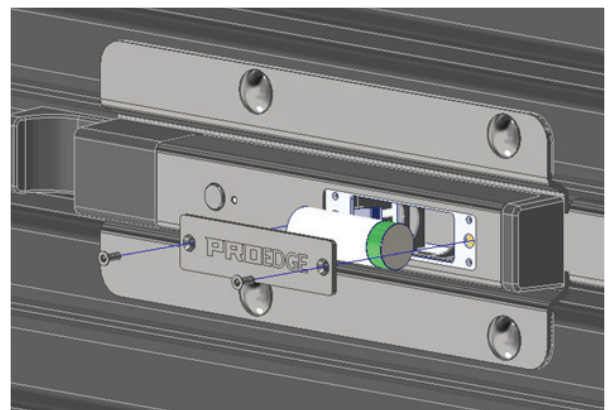

Do not install batteries that do not comply with the specified battery type in this manual.



Remember to put the lock into “normal operating mode” via the commissioning app after installing the batteries.

#### ProEdge Lock Repeater



Make sure to put the repeater in “Battery changing mode” via the commissioning app to avoid any alarms in the backend.

1. Unscrew the 4 x battery screws on the front
2. Remove the screws and the lid
3. Take out the used battery and replace it with a new battery
4. Re-assemble the lid and screws
5. The batteries have now been replaced.

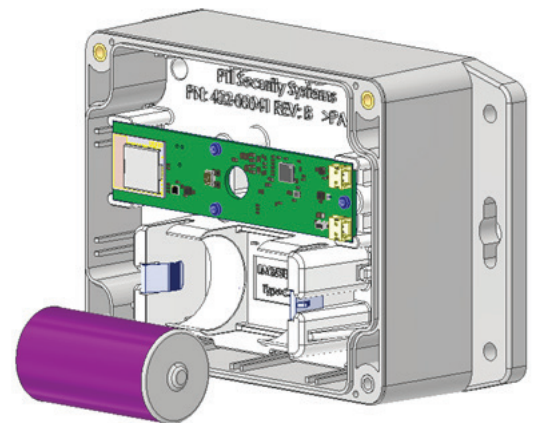

Do not install batteries that does not comply with the specified battery type in this manual.



Remember to put the lock into “normal operating mode” via the commissioning app after installing the batteries.

### PRODUCT DIMENSIONS AND WEIGHT

ProEdge lock for corrugated doors

Weight: 850g

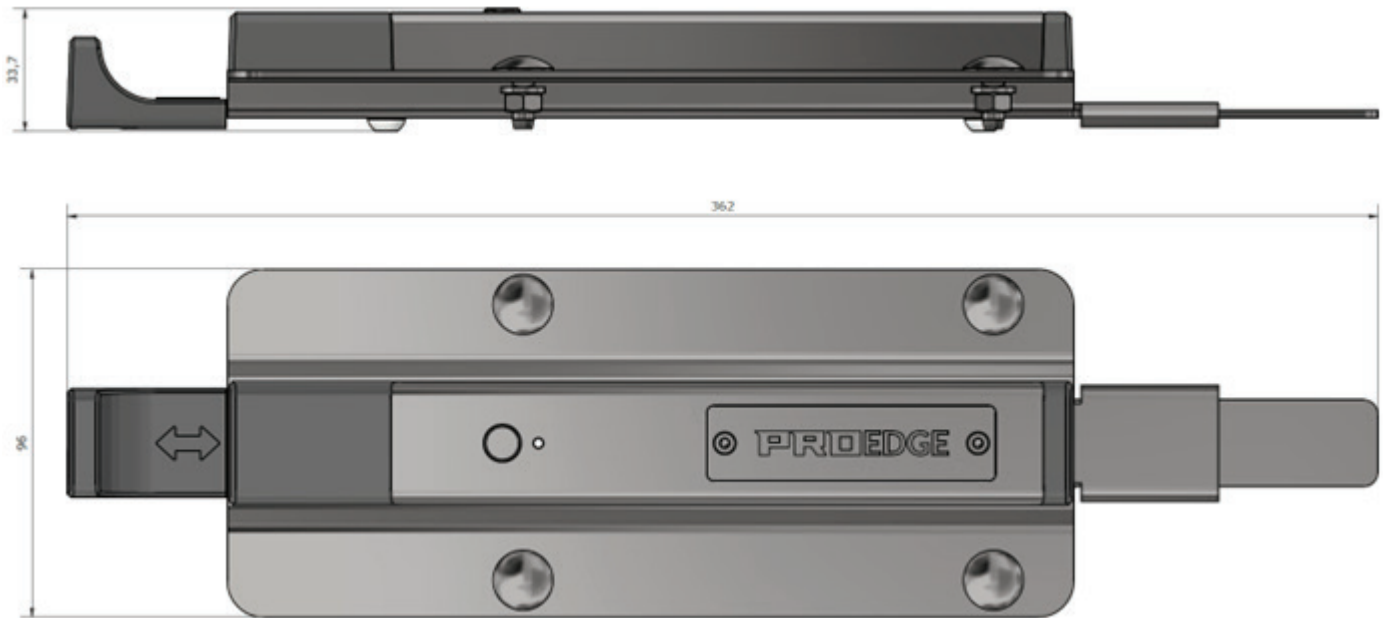

ProEdge lock for flat doors

Weight: 700g



### Operation Instructions

This section will give the reader an introduction to the unlocking and locking operation of the ProEdge lock in a step-by-step process.

### Unlocking the ProEdge lock

In the locked state approach, the lock and firmly press the button on the front of the lock. The LED indicator will flash blue when the lock has been activated.

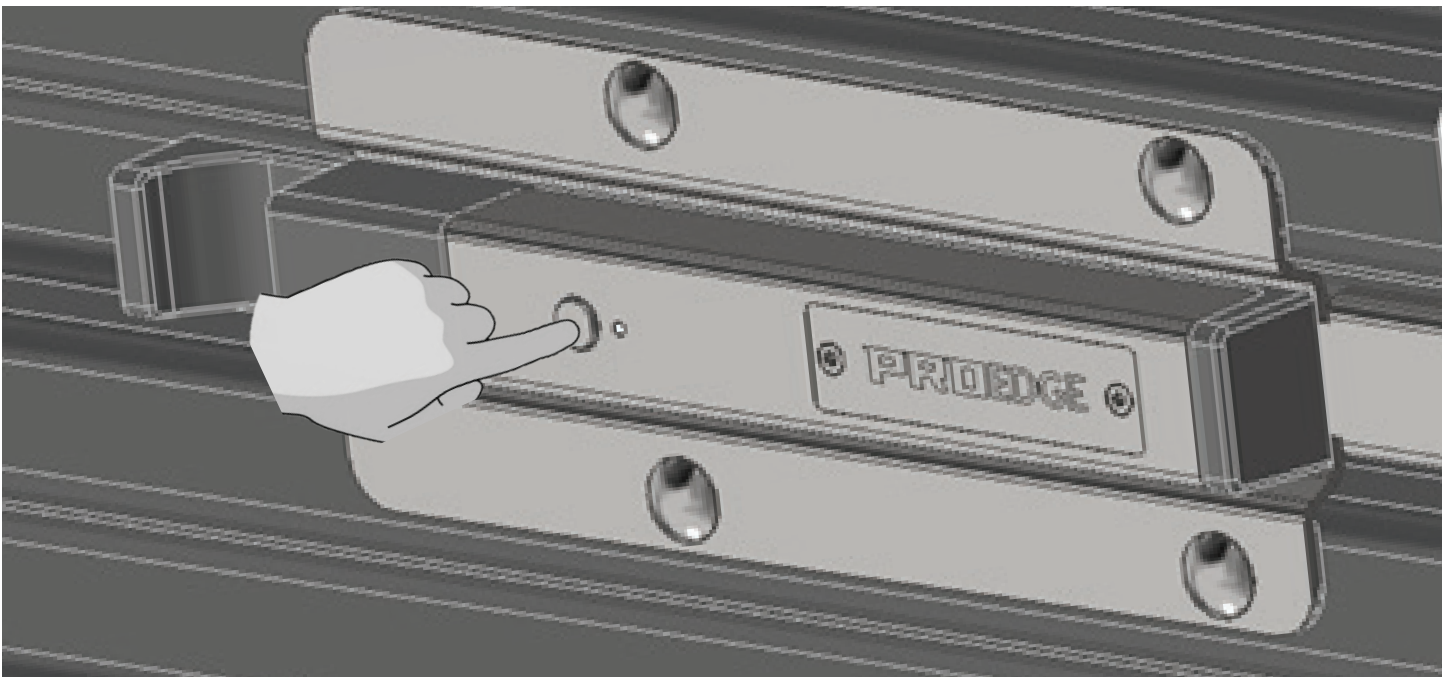

### Operating Instructions Guide:

Upon the smart lock awakening, the Tenant should have the mobile application open.

The BLE connection will automatically identify the “awakened lock,” verify the Tenant’s permissions, and initiate the “Open the lock” dialogue in the StorID app.

Swipe right in the mobile application to unlock the lock.

In exceptional situations, a Tenant may have multiple rented units in the same location, and multiple smart locks may awaken simultaneously. To address this scenario, we have implemented an additional dialogue. In this dialogue, the Tenant can selectively choose the specific lock they intend to open.



If the lock hasn’t been awakened before opening the mobile application, the app will prompt the tenant with a reminder to initiate the awakening process.



Note: The app currently does not have a locking function, so the Tenant must manually ensure that the lock is securely locked.

After swiping “open” in the StorID app, the lock will flash green for app. 3 seconds and a small “buzz” from the lock can be heard.

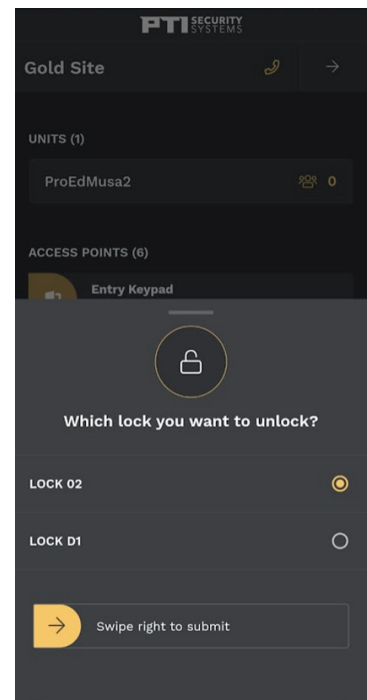
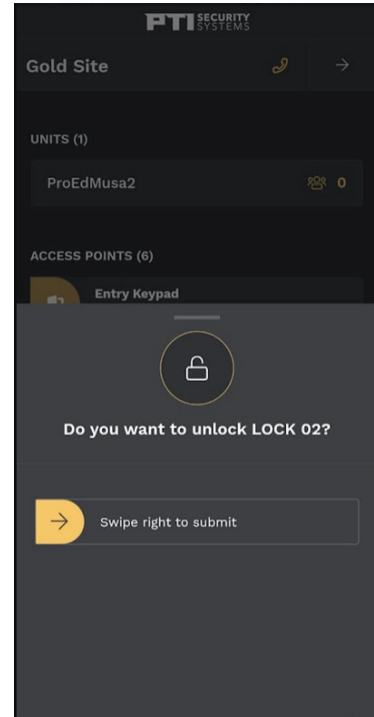

Gently pull the handle in the direction shown (Unlocked state).

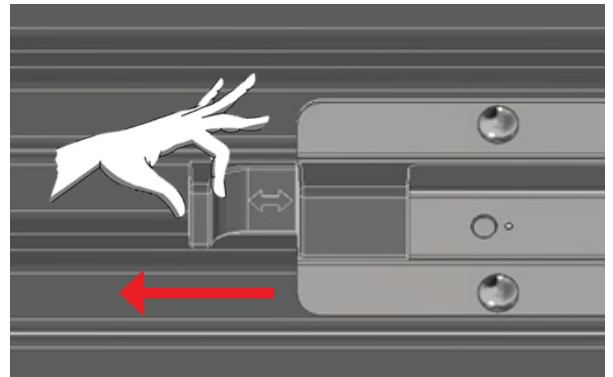

Make sure that the slider has been extracted all the way.

The user can now open/roll-up the door and access the unit.

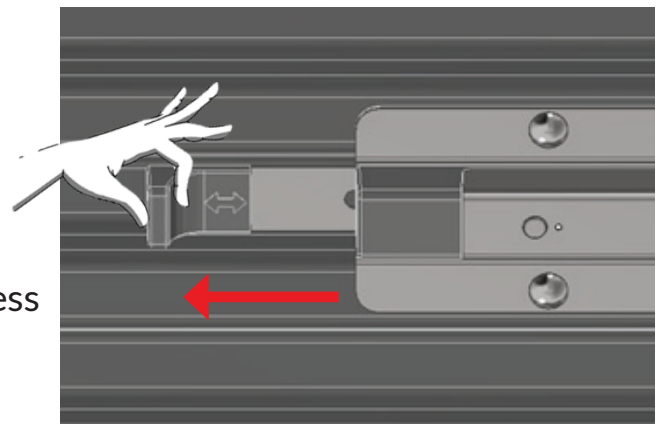

### LOCKING THE PROEDGE LOCK

When the user is ready to lock, close the door/roll down the door completely.

Make sure that the door has been rolled all the way down to avoid collisions between the slider and doorframe, making it hard to slide the slider into the locked position.

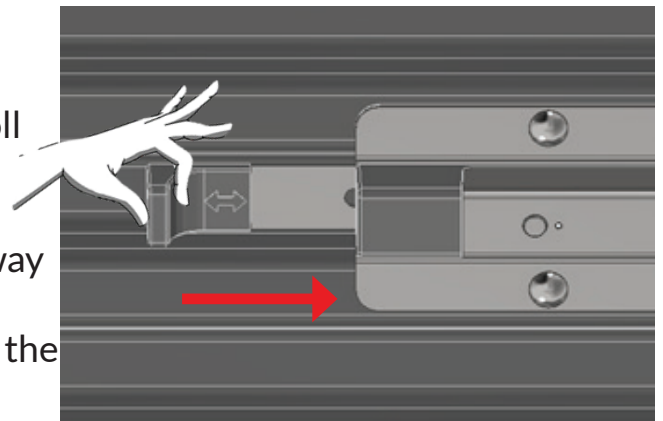

Gently push the handle in the direction shown (Locked state).

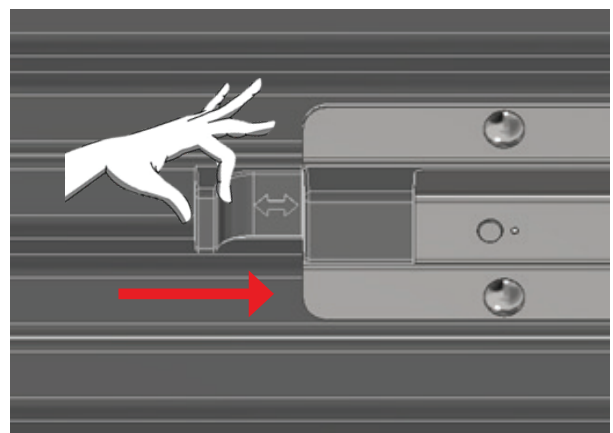

Make sure that the slider has been pushed all the way and firmly press the button.

The LED indicator will flash red for app. 3 seconds

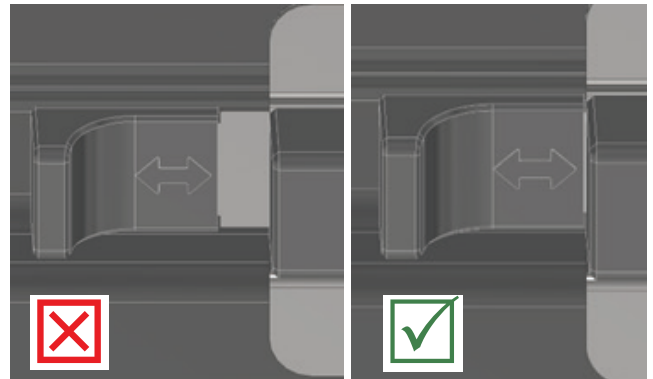

Confirm that the lock is locked properly but moving/wiggling the slider as shown.

The ProEdge lock for flat doors works in the exact same way as the shown corrugated version.

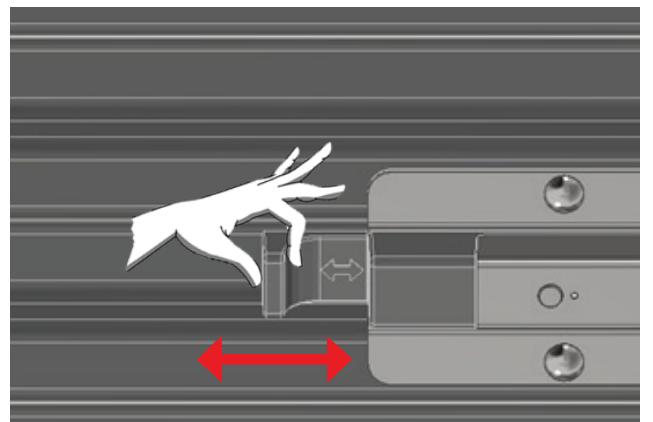

### MAINTENANCE AND CARE

- The ProEdge lock does not need any maintenance on a regular basis, and can be cleaned with a cloth, water and mild soap.
- Do not attempt to disassemble the digital door lock by yourself. By doing so, you may damage the product.
- Do not use force with a tool onto the product.
- Do not use any type of solvent to clean the product such as gasoline or benzene as they can cause damage to electronic circuit, deterioration and/or paint peel-off.
- Do not use any other batteries other than what is specified in this manual.
- Do not pressure wash.
- Make sure to follow the above instructions to avoid any injuries and/or damage to the product.

### DISPOSING OF THE PRODUCT - WEEE

The symbol on the products, packaging and/or accompanying documents mean that used electrical and electronic equipment/products should not be mixed with general household waste.

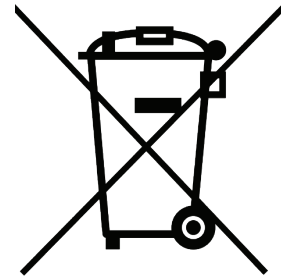

For proper treatment, recovery and recycling of old products, please bring them to applicable collection points in accordance with your national legislation and the following directives: Directives 2002/96 EC and 2006/66 EC.

By disposing of these products correctly you will help saving valuable resources and prevent any potential negative effects on human health and the environment which could otherwise arise from inappropriate waste handling.

For more information about collection and recycling of old products, please contact your local municipality, your waste disposal service or the point of sale where you purchased the product(s).

Penalties may be applicable for incorrect disposal of this waste, in accordance with national legislation.

For business users in the European Union:

If you wish to discard electrical and electronic equipment, please contact your dealer or supplier for further information.

Information on disposal in other countries outside the European Union:

These symbols are only valid in the European Union. If you wish to discard these products, please contact your local authorities or dealer and ask for the correct method of disposal.



### FREQUENTLY ASKED QUESTIONS (FAQ)

#### The lock does not react when I push the button?

- ☞ Make sure that the battery has power. Replace the battery if needed and try again.

#### The lock won't unlock when I swipe in the app?

- ☞ The lock may not have awakened yet or could be in a sleep state, rendering BLE recognition unavailable.
- ☞ The lock may be damaged or lose its connection.
- ☞ The lock may not be within range of a stable and functioning Bluetooth connection.
- ☞ Ensure the app has necessary permissions to control the lock. You can check the app settings to verify this.

#### The slider can't slide all the way, it's like its blocked?

- ☞ Many roll-up doors in self-storage need to be pressed down a bit before the slider can be retracted (For roll-up doors).
- ☞ The same goes for flat doors – make sure that the slider is not in tension.
- ☞ In both cases, try to wiggle the door while sliding in the locked/unlocked position.

#### The handle accidentally fell off when I pulled it, what do I do?

- ☞ The handle is designed to fall off if exposed to excessive force. This is a feature to avoid leveraging any tools/crowbars to force open the lock.
- ☞ The handle can however easily be snapped onto place again with the snap fit.

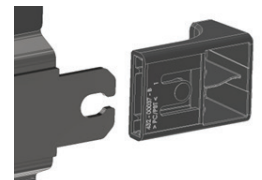

#### Why can't I pressure wash my lock?

- ☞ The lock is designed to withstand ingress to a certain extent.
- ☞ It can withstand rain and operate in most environments, but high-pressure water jets are very powerful and will damage the button assembly and potentially force water in between the gaskets, resulting in corrosion and malfunctioning electronics.

#### Why does the mobile app work poorly when I do not have any cellular connection?

- ☞ The mobile application's full performance may be compromised when the internet connection is poor or unavailable.
- ☞ The application is designed to function optimally with a stable internet connection to maximize its user-friendly features.
- ☞ In the absence of a connection, the application's capabilities will be limited to using BLE solely for the purpose of opening the smart lock.

### WARRANTY & DISCLAIMER

PTI Security Systems warrants its products and equipment to conform to its own specifications and to be free from defects in materials and workmanship, under normal use and service, for a period of one year from the date of shipment. Within the warranty period, PTI Security Systems will repair or replace, at its option, all or any part of the warranted product which fails due to materials and/ or workmanship. PTI Security Systems will not be responsible for the dismantling and/or re-installation charges. To utilize this warranty, the customer must be given a Return Materials Authorization (RMA) number by PTI Security Systems. The customer must pay all shipping costs for returning the product.

This warranty does not apply in cases of improper installation, misuse, failure to follow the installation and operating instructions, alteration, abuse, accident, tampering, natural events (lightning, flooding, storms, etc.), and repair by anyone other than PTI Security Systems.

This warranty is exclusive and in lieu of all other warranties, expressed or implied, including but not limited to the implied warranties of merchantability and fitness for a particular purpose. PTI Security Systems will not be liable to anyone for any consequential or incidental damages for breach of this warranty or any other warranties.

This warranty will not be modified or varied. PTI Security Systems does not authorize any person to act on its behalf to modify or vary this warranty. This warranty applies to PTI Security Systems products only. All other products, accessories, or attachments used in conjunction with our equipment, including batteries, will be covered solely by their own warranty, if any. PTI Security Systems will not be liable for any direct, incidental, or consequential damage or loss whatsoever, caused by the malfunction of product due to products, accessories, or attachments of other manufacturers, including batteries, used in conjunction with our products. This warranty does not cover the replacement of batteries that are used to power PTI Security Systems products.

The customer recognizes that a properly installed and maintained security system may only reduce the risk of events such as burglary, robbery, personal injury, and fire. It does not ensure or guarantee that there will be no death, personal damage, and/or damage to property as a result. PTI Security Systems does not claim that the Product may not be compromised and/or circumvented, or that the Product will prevent any death, personal and/or bodily injury and/or damage to property resulting from burglary, robbery, fire, or otherwise, or that the Product will in all cases provide adequate warning or protection. PTI Security Systems products should only be installed by qualified installers. The customer is responsible for verifying the qualifications of the selected installer.

PTI Security Systems shall have no liability for any death, injury, or damage, however incurred, based on a claim that PTI Security Systems Products failed to function. However, if PTI Security Systems is held liable, directly or indirectly, for any loss or damage arising under this limited warranty or otherwise, PTI Security Systems's maximum liability will not in any case exceed the purchase price of the Product, which will be fixed as liquidated damages and not as a penalty, and will be the complete and exclusive remedy against PTI Security Systems.

**Warning:** The User should follow all installation, operation, and maintenance instructions. The User is strongly advised to conduct Product and systems test at least once each week. Changes in environmental conditions, electric or electronic disruptions, and tampering may cause the Product to not perform as expected.

**Warning:** PTI Security Systems warrants its Product to the User. The User is responsible for exercising all due prudence and taking necessary precautions for the safety and protection of lives and property wherever PTI Security Systems Products are installed. PTI Security Systems does not authorize the use of its Products in applications affecting life safety.

**Notice.** Some PTI Security Systems products use 900Mhz wireless technology. Other devices at the site such as cordless telephones or alarm components may cause interference that will disrupt the operation of the system or may be interfered with by the system. PTI Security Systems assumes no liability for any problems caused by interference. It is the sole responsibility of the user to identify and correct such problems.

**For technical support, please call our live support team at +1.866.240.7602 Monday-Friday; 10:00am-7:00pm EST.**



### Changelog

Date	Change
11-27-2023	New document

# PTI SECURITY SYSTEMS

# ASSA ABLOY

SHAPING THE INDUSTRY  
SINCE 1979

With PTI Security Systems, operators can easily customize all of their facility's access areas, review site activity, and monitor zones and alarms from one cloud-based account. Create a world-class operation with the most advanced enterprise access control solution from the trusted industry leader with over 40 years of experience.

Since 1979, PTI Security Systems™ has provided the self-storage industry with proven security and access control systems. Known for our complete and innovative solutions that deliver advanced and cost-effective security systems, self-storage owners and operators can efficiently manage their facility from anywhere, lower operating costs, and enhance the tenant experience.

For more information about PTI Security Systems, please contact a PTI representative or visit our website.

PTI is a trademark of Preferred Technology Systems, LLC

 [ptisecurity.com](https://ptisecurity.com)

 [sales@ptisecurity.com](mailto:sales@ptisecurity.com)

 800.523.9504